

Label Inspector

PRODUCT INFORMATION



THE LABEL INSPECTOR ENSURES CORRECT LABELING

Quality control is essential in delivering a product with correct product information towards the customer since customers are getting more and more demanding.

Food products have an added dimension; with today's strict regulations it is very important that food products have correct and readable labelling for the consumer. The Label Inspector (LI) helps you to verify correct labelling and printed information.

The LI checks the packaging:

1. for presence of any labelling and printed information
2. for correct, readable label/printed information

The LI inspects both sides of the packaging

The label inspector is able to inspect multiple labels, expiration date and barcode simultaneously.

- ▶ Presence of expiration date
- ▶ Expiration date
- ▶ Label(s)
- ▶ Presence of barcode
- ▶ Foil displacement
- ▶ Action sticker

180 products/minute 24/7

The Label Inspector [launch March 2012] can be ordered with art no. 100377

- ▶ Small size, fiber tech housing
- ▶ No calibration required
- ▶ Easy use by automatic learning using barcode scanner
- ▶ Characters from 2.5 mm in height can be read
- ▶ Speed of the belt: max. 60 m/minute
- ▶ Barcode detection, all colors (even red and green)



The 2012 Label Inspector can be upgraded to full Seal Inspector (www.sealinspector.com)

Label Inspector

PRODUCT INFORMATION

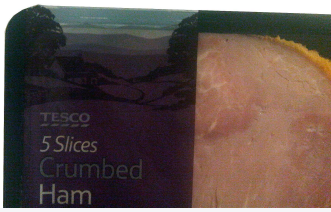

Specifications

- ▶ 100% inspection of the label
- ▶ Up to 180 products per minute
- ▶ Minimal character size 2.5 mm for reading
- ▶ Label inspection on top and bottom of the product
- ▶ The label Inspector inspects 100% of your production volume with a accuracy better than 1:5,000.

Benefits

- ▶ 100% of all products inspected
- ▶ Non-contact inspection
- ▶ Historical production information
- ▶ No return of products
- ▶ Higher customer satisfaction

Features

- ▶ Easy installation at existing lines. Equipment needs 760 mm space
- ▶ Height of the belt is 850 mm \pm 50 mm
- ▶ Inspection settings adjustable during production
- ▶ Possibility to view all images, selected images or only rejects per measurement
- ▶ Low maintenance and easy replacement of mechanical parts
- ▶ No photo electric cells used for product detection in the Seal Inspector (only at rejector),
- ▶ Try-out settings using review or production images
- ▶ Remote access by VPN, eWON or Teamviewer
- ▶ Grant access to various user definable levels
- ▶ Recipes (set of inspection parameters) can be stored and retrieved easily

Explanation of User Interface

- ▶ Control buttons at the top of the screen
- ▶ Left is Top view of product
- ▶ Right is Bottom view of product
- ▶ The measurement areas are indicated by rectangles and regions of interest (can be switched off)
- ▶ Statistical information at the bottom of the screen

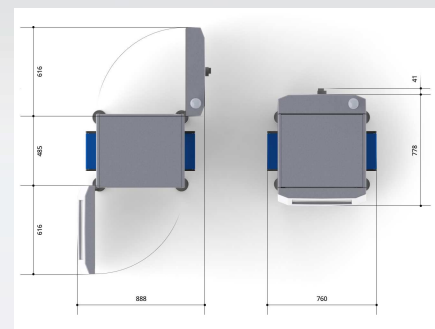

Topview Label Inspector opened/closed

Contact

For more information or a live demonstration, please contact us at:



- ▶ Telephone : +31 (0)76 54 40 588
- ▶ E-Mail : sales@machinevision.nl
- ▶ Website : www.labelinspector.com

Minervum 7069, 4817 ZK Breda, The Netherlands • PO Box 5616, 4801 EA Breda, The Netherlands

Telephone +31 (0)76 544 0588 • Fax +31 (0)76 541 7893 • Website www.machinevision.nl • Email sales@machinevision.nl